

Amp with Tone Controls & Soft Switching

Description:

Built around an LM380, this amplifier includes tone controls and electronic "soft switching". The soft switching circuitry ensures power is built up gradually eliminating the dc thump.

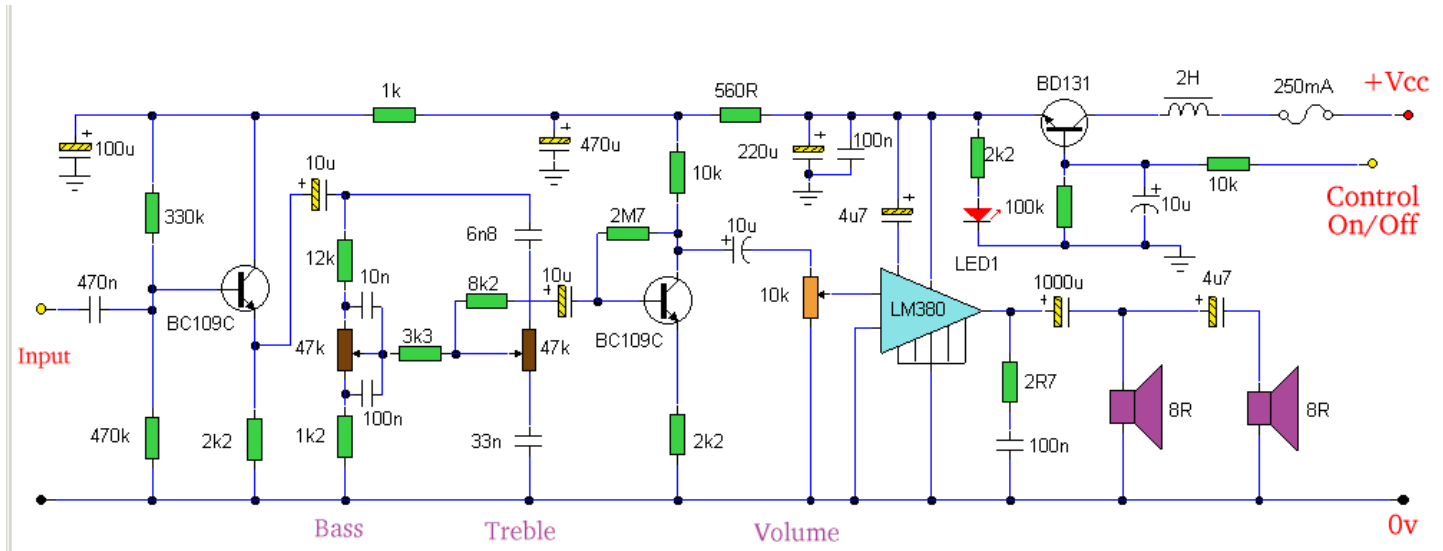

Notes:

The soft switching is enabled by a BD131 transistor wired as a switch in emitter follower configuration. The collector is wired to a permanent supply voltage, the 2H series inductor serves only to filter out power supply hum. This inductor is not too important and may be omitted if the DC supply is adequately smoothed. The control voltage is applied to the BD131 base terminal, the 10uF capacitor and 10k resistor having a dual purpose:-

- a gradual charge of the 10uF capacitor ensures that the transistor will switch linearly from 0 volts to full supply, and
- serves as a hum filter ensuring a very smooth dc supply to the amplifier and tone controls.

LED1 will light when the amplifier is on. The control voltage should ideally be 0 volts when the amplifier is off and full supply voltage when on. The LM380 is shown driving two 8 ohm loudspeakers, the load is therefore 4 ohms. The 4u7 capacitor acts as a crude crossover, lower frequencies are impeded and so this loudspeaker may be a "tweeter" type.

Tone Controls:

The input of this amplifier is via a tone control based on the baxendall design. The first BC109C serves as a buffer, offering a high input impedance. The output signal fed via a 10uF capacitor reaches the tone control network. This passive network of resistors and capacitors attenuates high and low frequencies. The bass control is centered on 100Hz and treble control 10kHz. The second BC109C amplifies the losses from the tone control, overall the tone control provides roughly +6dB boost and -20dB cut. See the bode plot below:

Bode response of Tone Controls:

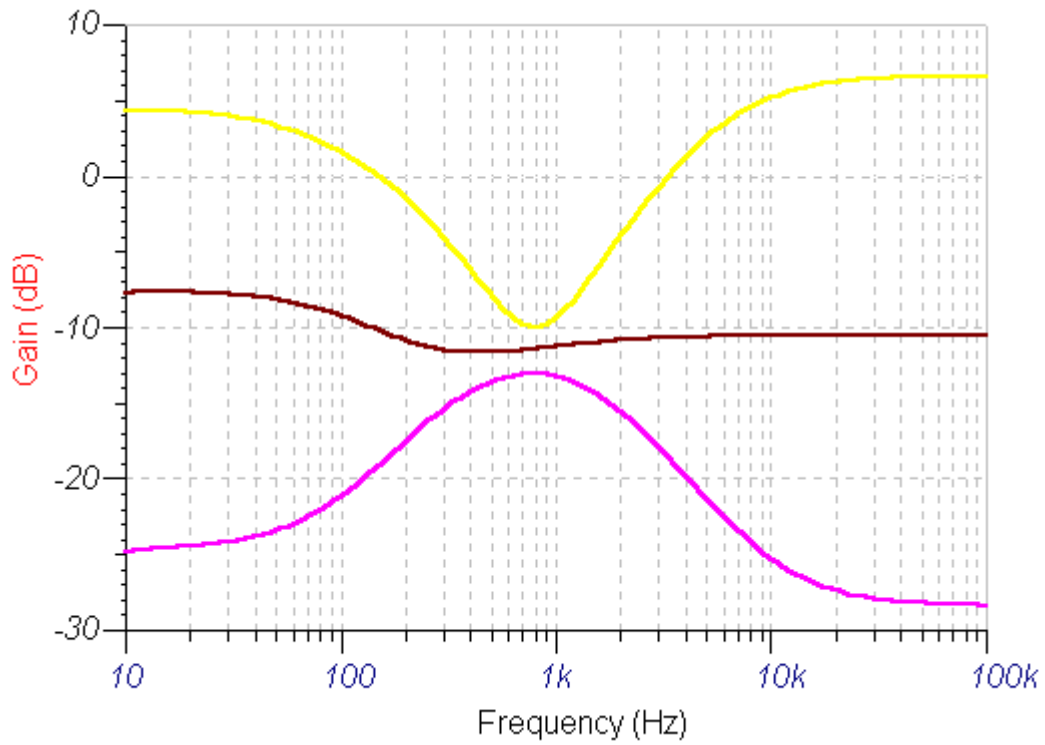

The traces show maximum lift, maximum cut and the response with tone controls in the centre position. There may be difficulty in obtaining BC109C transistors, but BC108C transistors will make an ideal replacement.